



Factories



Packaging centers



Catering

**Ideal** for all kinds of products and especially pre-cooked.

**Suitable** for medium productions with the possibility of a constant mold change.

**Recommended** for all sectors, where product preservation, good presentation and ease of storage and cleaning be required.

The **TSB-100 / A-100** are ideals for:



Cheeses



Sausages



Meats



Fish and seafood



Vegetables



Pastas and pizzas



Nuts



Sauces



Coffee



Pastries



Non-Food



Perimeter cut and seal. Entry and exit using the automated drawer in the TSB-A-100 or done manually in the TSB-100.



Automated system for excess film collection, controlled by a system taking maximum advantage of its use.

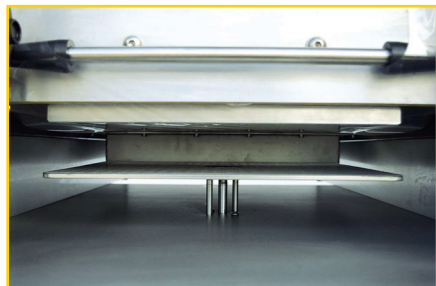

Rising mould platform



Two button activation for automated entry in the drawer. The exit is done automatically when the cycle is finished (convenient for cold product packaging).



Form's fast change command.



Control film step

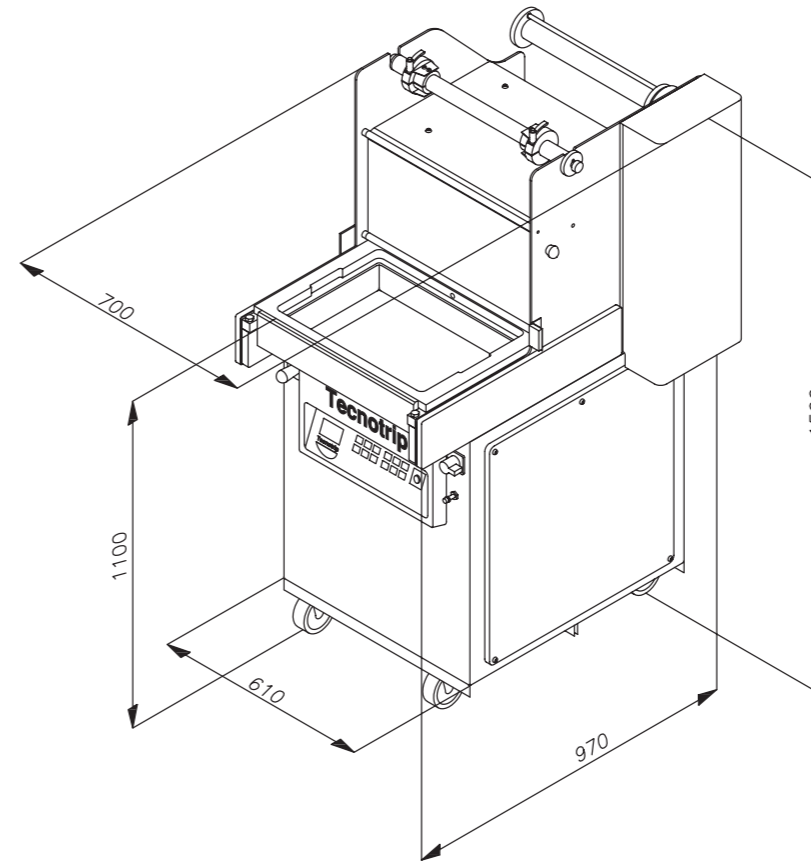

**For preformed trays**

**Maximum tray dimensions**

(Mold 1 cavity)

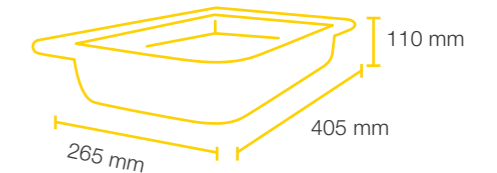

**Maximum tray dimensions**

(Mold 2 cavities)

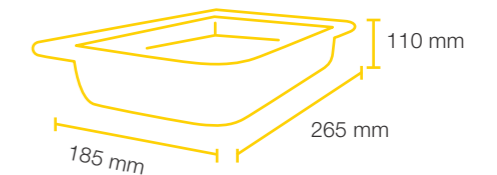

**Molds**



1 cavity:  
1x 320x260 mm  
1/2 G



2 cavities:  
2x 260x160 mm  
1/4 G



4 cavities:  
4x 170x130 mm  
1/8 G

Possibility  
special molds

**Packaging programs**

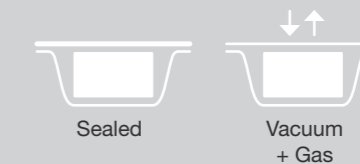

**Gas**



**Semi-automatic vacuum (or without) tray sealer for preformed trays. Vacuum packaging with modified atmosphere, for greater conservation, better presentation, as well as easy of storage and transport.**

**Features**

- Entry and Exit drawer:
- Easy maintenance and cleaning
- Manufacture according to CE standard
- Independent sealing system between trays
- Perimeter cut and seal
- Automated system for excess film collection
- Change of mold without tools

	TSB-A-100	TSB-100
Entry and Exit drawer:	automatic	manual

**Technical data**

	TSB-A-100	TSB-100
Exterior dimensions/mm:	610x970x1500	610x970x1500
Maximum tray dimensions/mm:	265x405x110	265x405x110
Maximum coil dimensions/mm:	260x470	260x470
Cycles/min:	3/6	3/6
Power/Kw:	1,5	1,1
Electrical connection:	220/380v 50/60hz 3Ph	220/380V 50/60Hz 3Ph 220V 50/60Hz 1Ph

Compressed air/bar:	6	6
Weight/kg:	210	210

**Equipment**

Pump:m <sup>3</sup> /h	63 m <sup>3</sup> /h	40 m <sup>3</sup> /h
Digital programmer	CD system	CD system
Gas		

**Information about the digital programmer**

- 30 programs to select
- Vacuum control by sensor
- Supplementary vacuum function
- Progressive vacuum program
- Progressive air inlet "SOFT-AIR"
- Vacuum verification program
- Manual stop vacuum
- Cycle counter
- Oil change control
- Pump preheating program
- Sealing control
- \*see descriptions on the web

**Accessories and consumables**

Trays and film

**Tecnotrip, S.A.**

C/ L'Alguer, 22 · Pol. Ind. Nord  
08226 Terrassa (Barcelona) España  
Tel.: +34 93 735 69 69  
WhatsApp: 695 781 799  
tecnotrip@tecnotrip.com